

INTERNAL CIRCUIT

VOLTAGE OUTPUT

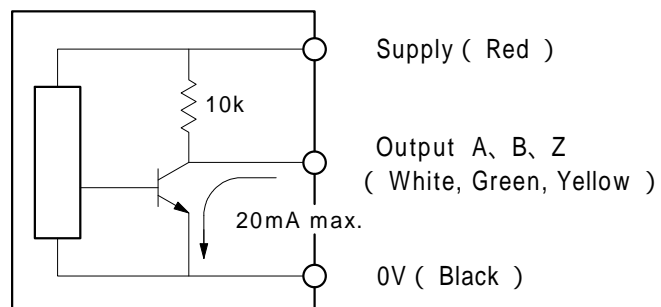

Supply voltage (DC 5V)

OUTPUT WAVEFORM

At CCW of rolling wheel

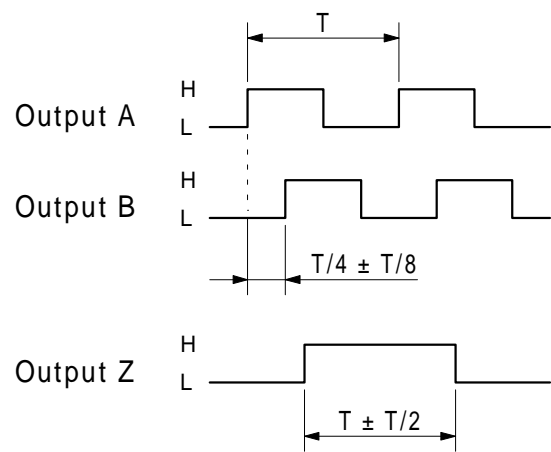

The position of the output Z to the output A and B is not specified.

DIMENSIONS

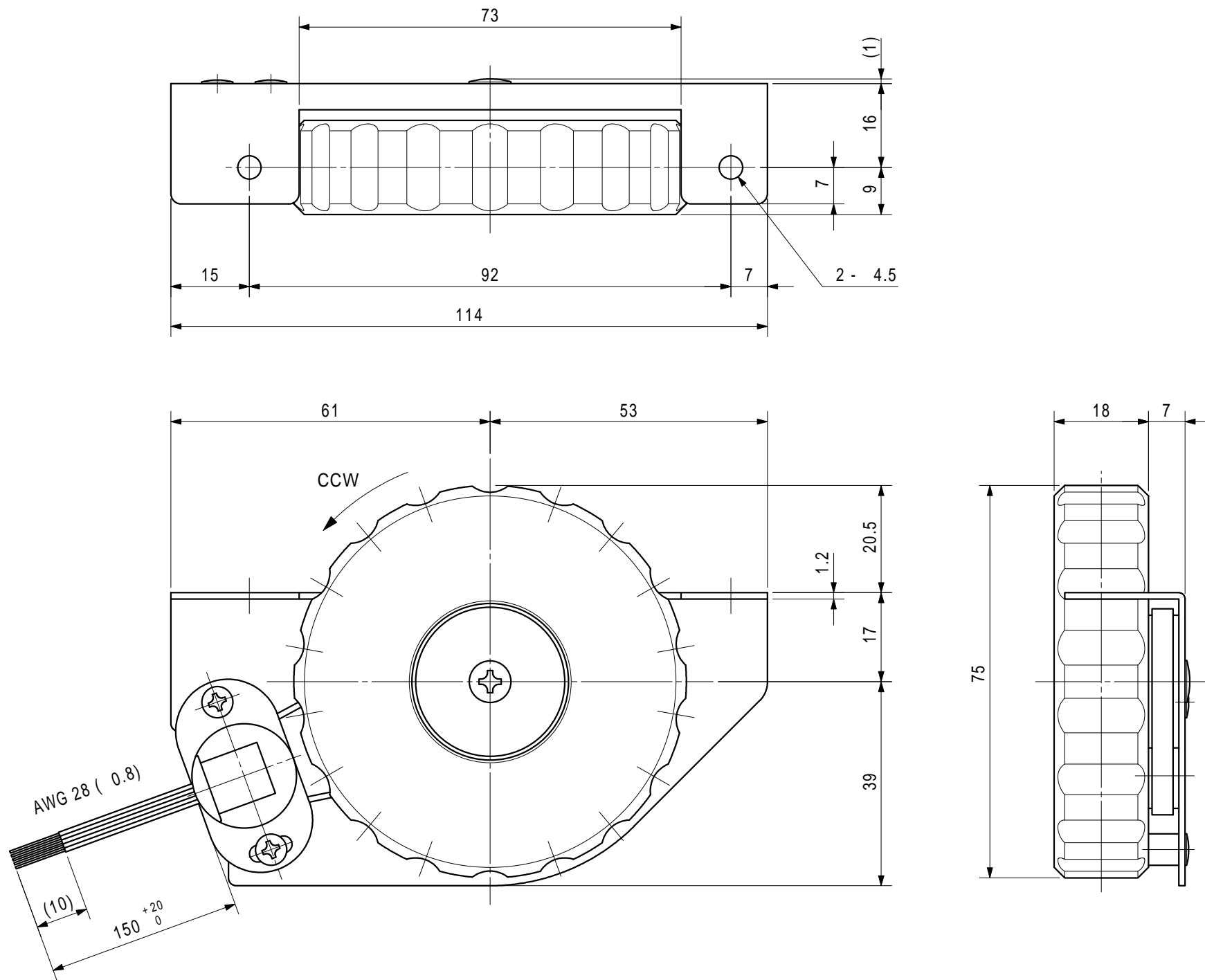

REVISION	DATE	DESCRIPTION	DRAWN	CHECKED	APPROVED	MATERIAL	MODEL
4			6. Oct. 2019				FVEW5D-400
3			A.Ohtaki				Endless Wheel
2							
1							
SEET NO.		NOTE	SCALE		SURFACE FINISHING		DOCUMENT NO.
1 OF 1			1 / 1		FERVENT CONTROLS		