

PANEL CUT OUT

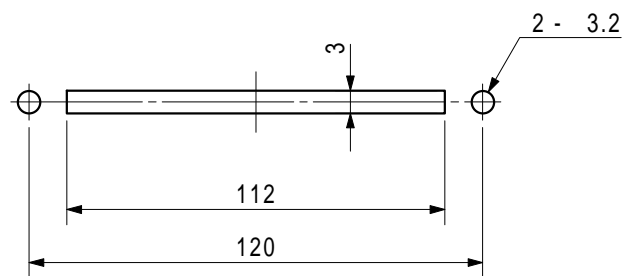

DIMENSIONS

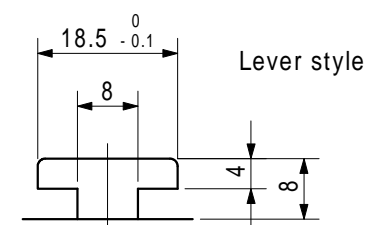
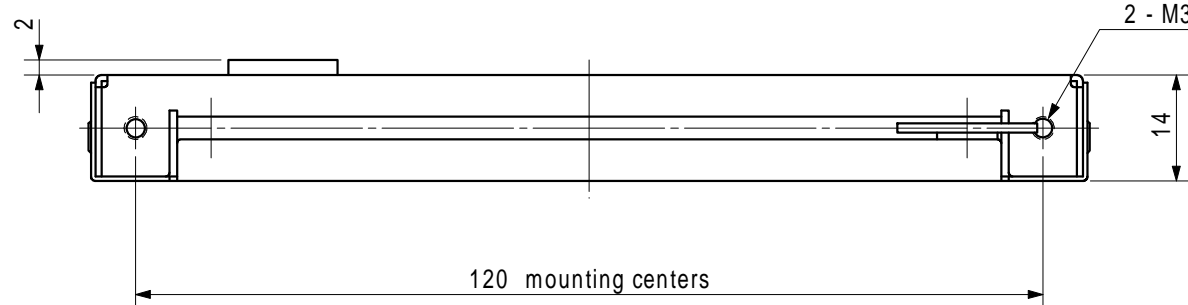

CIRCUIT DIAGRAMS

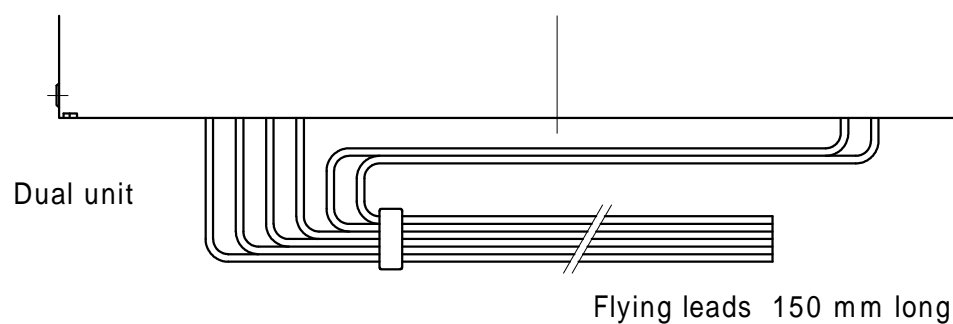
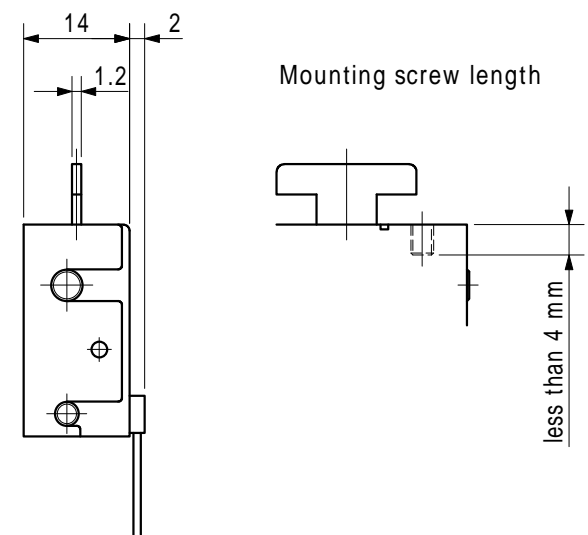
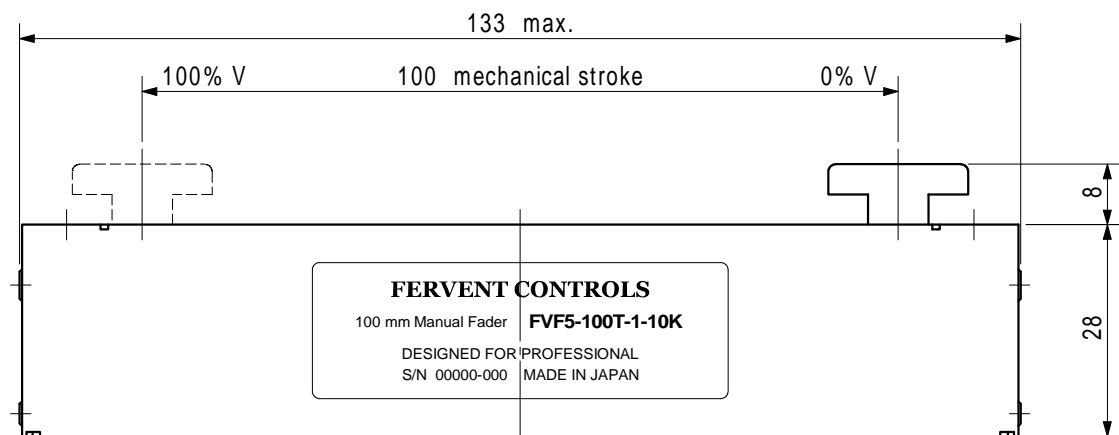
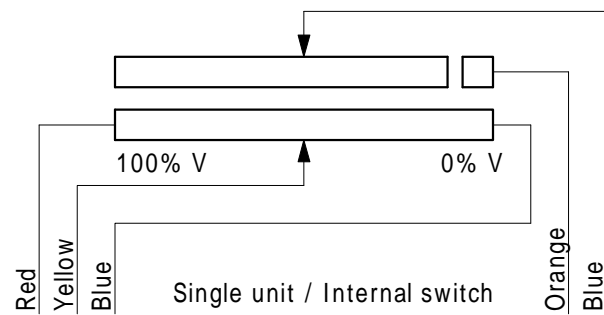
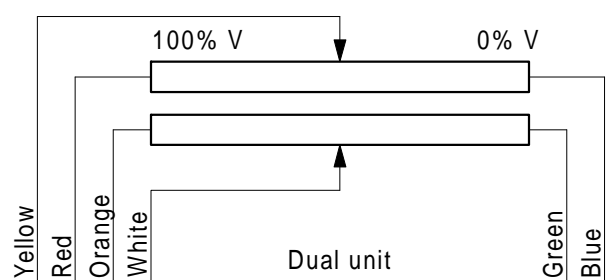
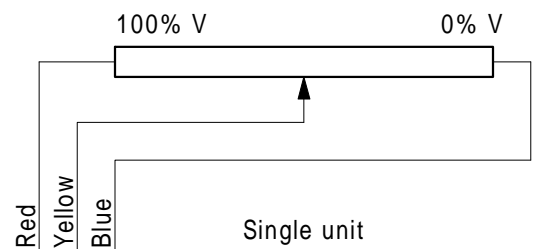

NUMBERING

FVF5 - 100 T - 1 - 10 K

- T Having sliding torque
- S Sooth feeling
- 1 Single unit
- 2 Dual unit
- 3 Single unit / Internal switch
- 10 Total Resistance 10k : Standard

REVISION	DATE	DESCRIPTION	DRAWN	CHECKED	APPROVED	MATERIAL	MODEL
4			12. Oct. 2019				FVF5-100
3			A.Ohtaki				Manual Fader
2							
1							
SEET NO. 1 OF 1		NOTE	SCALE 1 / 1		SURFACE FINISHING		DOCUMENT NO.