

PANEL CUT OUT

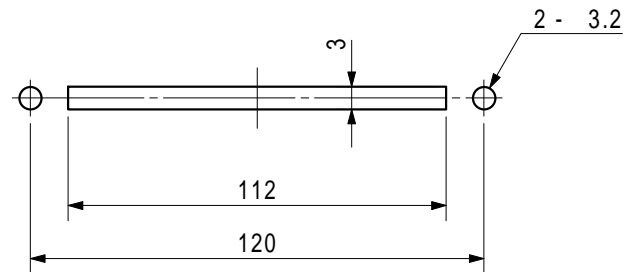

DIMENSIONS

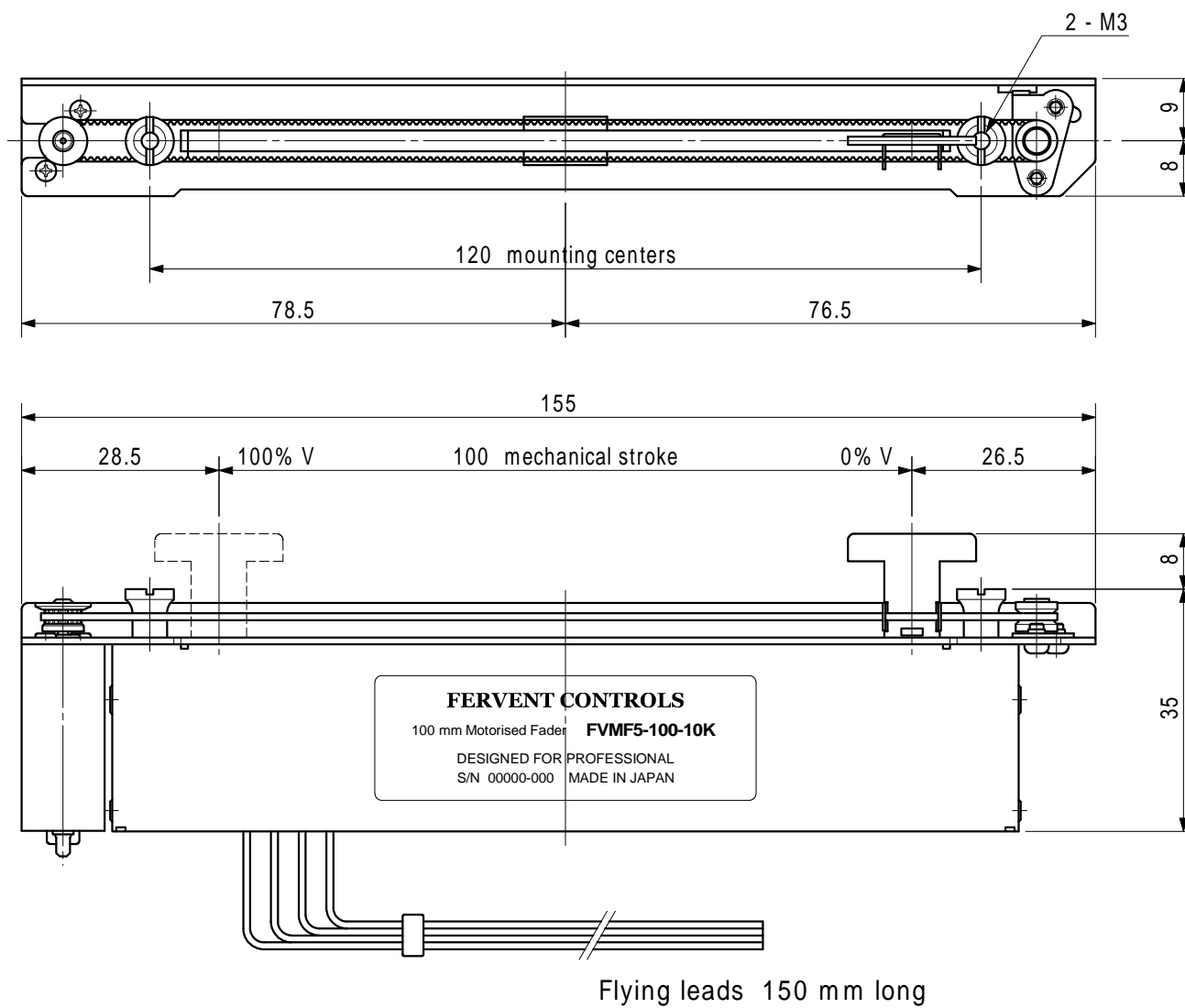

CIRCUIT DIAGRAMS

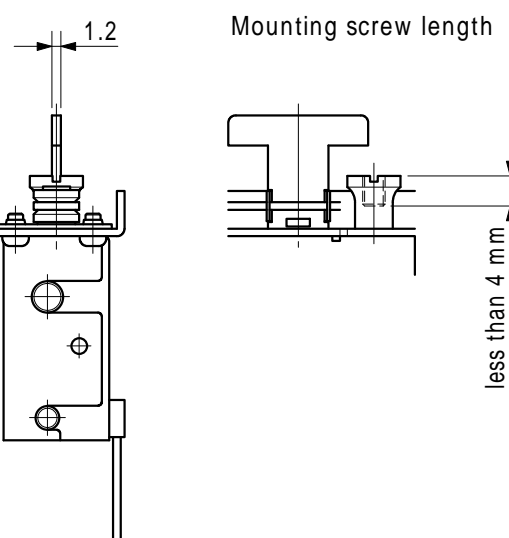
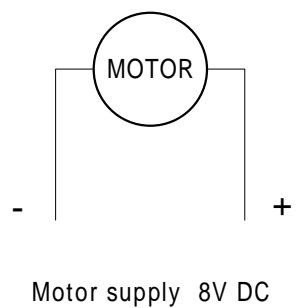
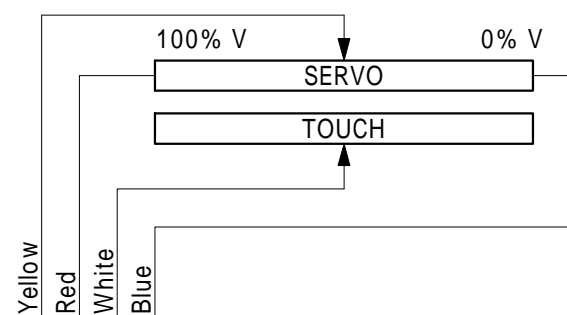

NUMBERING

FVMF5 - 100 - 10 K

10 Total Resistance 10k : Standard

REVISION	DATE	DESCRIPTION	DRAWN	CHECKED	APPROVED	MATERIAL	MODEL
4			6. Oct. 2019 A.Ohtaki				FVMF5-100
3						SURFACE PREPARATION	TITLE
2						SURFACE FINISHING	Motorised Fader
1							DOCUMENT NO.
SEET NO. 1 OF 1		NOTE	SCALE 1 / 1			FERVENT CONTROLS	